

NO.	DATE	REVISION RECORDS	REVISED	REVISION NO.
△	18/SEP/14	CHANGING HONDA PART NO. (3649)	KAWASE	-
△	23/SEP/14	ADDING PART NO. (3712)	KAWASE	-
△	19/NOV/14	CHANGING HONDA PART No.(3712)	MATSUZAKI	-

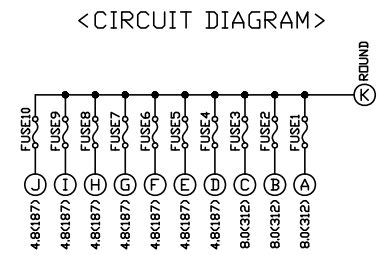
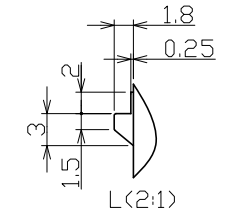
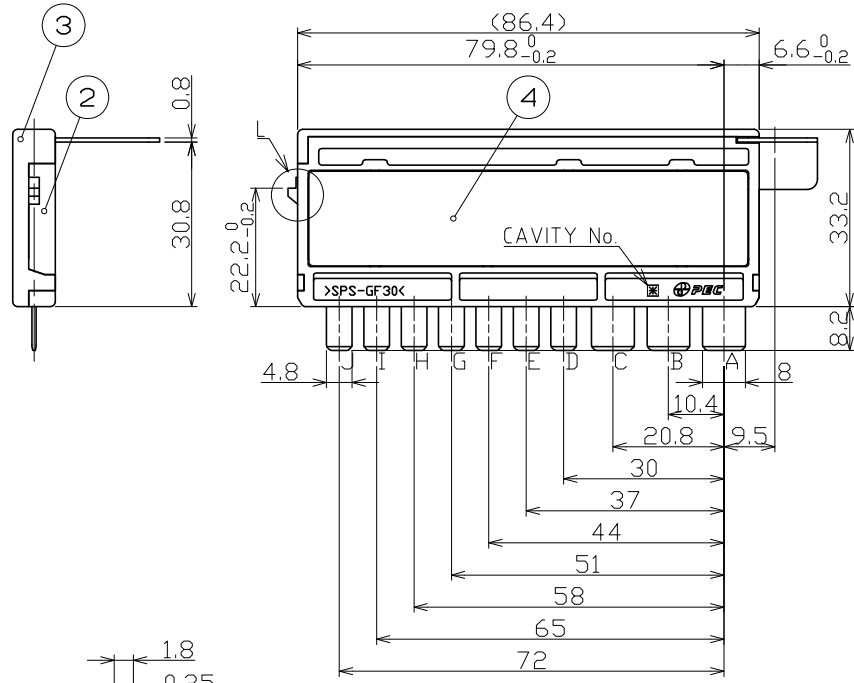
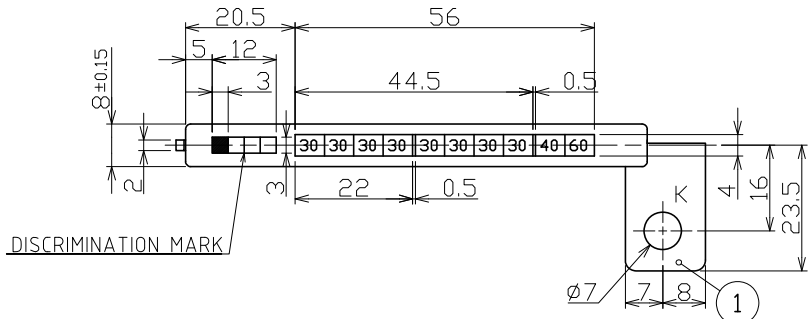

PEC PART NO.	36430011	36440011	36450011	36460011
PEC PART NAME	MUSB-P1-1	MUSB-P1-2	MUSB-P1-3	MUSB-P1-4
DISTINGUISHING MARK	■ ■ ■ ■	■ ■ ■ ■	■ ■ ■ ■	■ ■ ■ ■
FUSE1	60A	60A	60A	60A
FUSE2	40A	40A	40A	40A
FUSE3	30A	30A	50A	50A
FUSE4	30A	30A	30A	30A
FUSE5	30A	20A	30A	20A
FUSE6	30A	30A	30A	30A
FUSE7	30A	30A	30A	30A
FUSE8	30A	30A	30A	30A
FUSE9	30A	30A	30A	30A
FUSE10	30A	30A	30A	30A

36470011	36480011	36490011	37120011
MUSB-P1-5	MUSB-P1-6	MUSB-P1-7	MUSB-P1-8
■ ■ ■ ■	■ ■ ■ ■	■ ■ ■ ■	■ ■ ■ ■
60A	60A	60A	60A
50A	50A	30A	50A
60A	60A	60A	60A
40A	40A	40A	40A
30A	30A	20A	30A
30A	40A	30A	30A
30A	40A	30A	40A
30A	40A	30A	30A
20A	20A	20A	20A
40A	40A	30A	40A

4	-	COVER	2	PAR		CLEAR
3	-	HOUSING 2	1	SPS		BLACK
2	-	HOUSING 1	1	SPS		BLACK
1	-	ELEMENT	1	COPPER ALLOY	t0.8	
NO.	PART NO.	PART NAME	Q'TY	MATERIAL	SIZE	REMARKS

APPROVED	T. Nakagawa	DIMENSION TOLERANCE	ANGULAR TOLERANCE	FINISH
CHECKED	ml	±0.3	±2°	-
DESIGNED	F. Kawase	RUST PREVENTION	MATERIAL	
DRAWN	J. Matsuzaki	-	SEE TABLE	

SCALE	UNIT	DIAGRAM METHOD	PART NAME
1:1	mm	THIRD ANGLE PROJECTION	MUSB-P1
DRAWING DATE	DRAWING NAME	3D CAD DATA	PART NO.
19/NOV/14	G3643-0-8	-	SEE TABLE

NO.	DATE	REVISION RECORDS	REVISED	REVISION NO.
		REFER TO (1/2)		

PACKAGING SPECIFICATION

INNER PACKAGING
 PARTITION PAD
 △ PLASTIC TRAY
 △ SPACER
 PLASTIC BAG(780×700×0.07)

OUTER PACKAGING
 CORRUGATED BOARD BOX : YP0

CAPACITY:160 PCS

MARKING
 ID TAG

- △ 1.PUT PARTITION PAD AND PLASTIC TRAY INTO PLASTIC BAG. PUT 32 PRODUCTS(16PCS. PER 1 BLOCK) ONTO THE TRAY.
- 2.PILE NEXT PLASTIC TRAY ON FIRST ONE IN THE OPPOSITE DIRECTION. PUT 32 PRODUCTS ONTO THE TRAY AS SAME AS FIRST TIER.
- 3.PILE THE THIRD, FOURTH AND FIFTH TRAY AND PUT PRODUCTS IN THE SAME WAY.
- △ 4.PUT PARTITION PAD ON FIFTH TRAY, FURTHERMORE PUT SPACER ON THE TOP. AND PUT THEM INTO CARDBOARD BOX. FOLD THE BAG AND CLOSE THE BOX WITH PP TAPE. FINALLY PUT THE ID TAG ON THE SIDE OF THE BOX IN THE SPECIFIED POSITION.

PEC Manufacturing (Thailand) Ltd.		DELIVERY DATE
PART NAME: MULTI SBF TYPE - P - 1 - 1		
PART NO: 3643-001	QTY: 160 Pcs.	
LOT NO: 12AWD1 WEIGHT: 5(指定) Kg OPERATOR: SURAT		
DATE: 05 - 01 - 12A		

△(EXAMPLE)

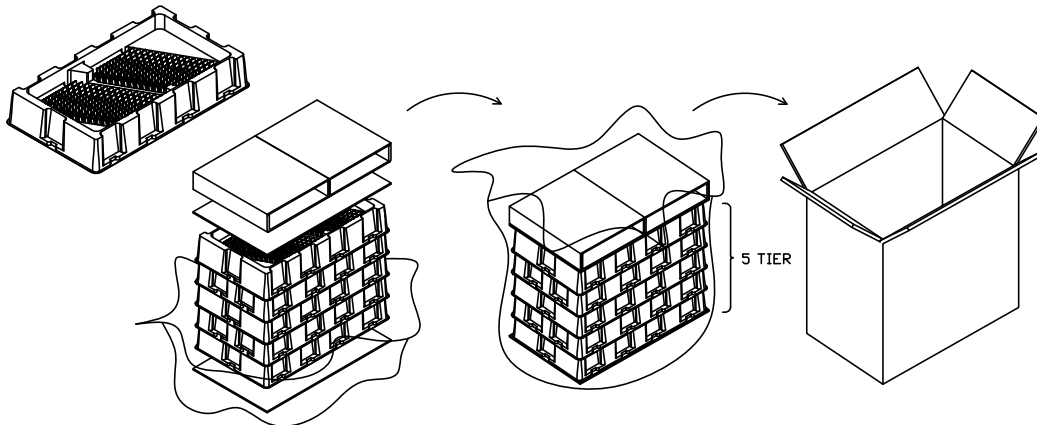

NO.	PART NO.	PART NAME	Q'TY	MATERIAL	SIZE	REMARKS	
APPROVED	<i>T. Nakagawa</i>	DIMENSION TOLERANCE		ANGULAR TOLERANCE	FINISH		
CHECKED	<i>me</i>	REFER TO(1/2)		REFER TO(1/2)	REFER TO(1/2)		
DESIGNED	<i>F. Kawase</i>	RUST PREVENTION		MATERIAL			
DRAWN	<i>J. Matsuyuki</i>	REFER TO(1/2)		REFER TO(1/2)			
SCALE: N.T.S		UNIT: mm	DIAGRAM METHOD: THIRD ANGLE PROJECTION		PART NAME: MUSB-P1		
DRAWING DATE: 19/NOV/14		DRAWING NAME: G3643-0-8		PART NO. REFER TO(1/2)			
Pacific Engineering Corporation						SHEET: 2 / 2	SIZE: A3