

注記

1. 上図は500Aヒューズを示す。
2. 製品の表示はレーザーマーカーにて印字する事。
3. A部には定格電流を表示する。
4. B部の数字は当社品番頭4桁を示す。
5. C部には当社製造Lot No.を表示する。

NOTE

1. THE DRAWING ABOVE SHOWS THE 500A FUSE.
2. THE CAUTION IS MARKED BY LASER MARKER.
3. "A" PORTION SHOWS RATED CURRENT.
4. NUMBER IN "B" PORTION SHOWS THE FIRST 4 DIGITS OF COMPANY PART No.
5. "C" PORTION SHOWS PEC'S PRODUCT LOT No.

NO.	DATE	REVISION RECORDS	REVISED	REVISION NO.
-	07/AUG/2017	NEWLY ESTABLISHED	H.ISHINAGA	-
△	06/APR/2020	DELETE OF ID TAG DESIGN. ADD NOTE.	H.ISHINAGA	-
△	03/JUL/2020	CHANGE BREAKING CAPACITY AND PART NO.	S.KATAOKA	-

仕様

1. 定格電圧 : 500VDC
2. 定格遮断容量 : 30000A △
3. 使用温度範囲 : -40℃~85℃
4. 保管温度範囲 : -40℃~85℃
5. ヒューズ性能 : 太平洋精工規格PES-A52-083に準ずる。
6. ヒューズの固定方法 : M8ボルト2本で固定。
7. PES-02-04の環境負荷物質の使用禁止・制限規定を遵守する事。

SPECIFICATIONS

1. RATED VOLTAGE : 500VDC
2. BREAKING CAPACITY : 30000A △
3. OPERATING TEMPERATURE LIMIT : -40℃...85℃
4. STORAGE TEMPERATURE LIMIT : -40℃...85℃
5. FUSE PERFORMANCE : PERFORMANCE OF THIS PART CONFORMS TO PES-A52-083.
6. FUSE FIXING METHOD : USE TWO M8 BOLTS.
7. COMPLY WITH ENVIRONMENTAL RESTRICTION AND PROHIBITION WHICH PRESCRIBED UNDER "PES-02-04".

定格電流 RATED CURRENT	△ *1)品番 *1)PART No.	△ *2)包装品番 *2)PACKAGING PART No.
350A	△ 29760010	△ 29760011
400A	△ 29770010	△ 29770011
450A	△ 29780010	△ 29780011
500A	△ 29790010	△ 29790011



*1)品番は単一のヒューズを示す。
*2)包装品番は、包装仕様で定義されている単一の包装 (段ボール箱) の品番を示す。

*1)PART NO. INDICATES A SINGLE FUSE.
*2)PACKAGING PART NO. INDICATES THE PART NO. OF A SINGLE PACKAGING UNIT (CARDBOARD BOX) AS DIFINED ON THE UNDER PACKAGING SPECIFICATION.

6	-	ADHESIVE	-	EPOXY-RESIN	-	-
5	-	ARC-EXTINGUISHING SAND	-	SILICA	-	-
4	-	CASE B	1	UNSATURATED POLYESTER	-	-
3	-	CASE A	1	UNSATURATED POLYESTER	-	-
2	-	RING	2	COPPER	-	-
1	-	ELEMENT	1	COPPER	-	-
NO.	PART NO.	PART NAME	Q'TY	MATERIAL	SIZE	REMARKS

APPROVED	<i>N. Shibata</i>	DIMENSION TOLERANCE	ANGULAR TOLERANCE	FINISH
CHECKED	<i>H. Shimizu</i>	±0.2	-	-
DESIGNED	<i>Shuya Kataoka</i>	RUST PREVENTION	MATERIAL	
DRAWN	<i>Shuya Kataoka</i>	-	SEE TABLE	

SCALE	UNIT	DIAGRAM METHOD	PART NAME
1:1	mm	THIRD ANGLE PROJECTION	EVFP-φ38 ***A
DRAWING DATE	DRAWING NAME	3D CAD DATA	PART NO.
03/JUL/2020	G2979-0-2	-	SEE TABLE

Pacific Engineering Corporation

SHEET 1 / 2
SIZE A3

包装仕様 PACKAGING SPECIFICATION

	内装 INNER PACKAGING	外装 OUTER PACKAGING
包装材 MATERIAL	トレー TRAY	ダンボール CARDBOARD BOX (390×260×195)
品番シール SEAL OF PART NO.	—	現品票/ID TAG
表示 MARKING	該当なし NOT APPLICABLE	⚠ 外装に現品票の貼り付けあり ID TAG ATTACHED ON OUTER PACKAGE
収容数 CAPACITY	⚠ 10pcs PER TRAY	⚠ 4 TRAYS TOTAL 40pcs PER BOX
重量 WEIGHT	1.4kg	6.2kg
方法 METHOD	1. トレーにヒューズを詰める。 2. 段ボールにPEシートを敷く。 3. ヒューズを詰めたトレーを4段積みで詰める。 4. PEシートで包んでから一番上にパッドをのせる。 5. テープで封をする。 6. 段ボール側面(現品票貼り付け位置)に現品票を貼る。	
	1. PUT THE FUSES IN THE TRAY. 2. SPREAD A PE SHEET IN THE CARDBOARD BOX. 3. STACK STUFFED TRAY WHICH FILLED WITH FUSES IN 4 LAYERS INTO THE BOX. 4. WRAP THEM BY THE PE SHEET AND PUT A PAD TOP OF THE BOX. 5. SEAL THE BOX BY TAPE. 6. PUT ID TAG ON THE SIDE OF CARDBOARD BOX.	
保管条件 SAFEKEEPING CONDITION	水ぬれ無き事。 湿度：-40℃~85℃、湿度：RH80%以下 KEEP DRY. TEMPERATURE LIMIT: -40℃~85℃、HUMIDITY: RH80% MAX.	

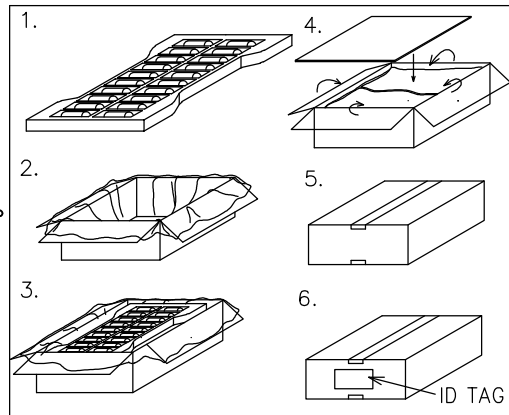

NO.	DATE	REVISION RECORDS	REVISED	REVISION NO.
—	—	REFER TO (1/2)	—	—
—	—	—	—	—
—	—	—	—	—

PACKAGING INFORMATION

APPROVED	<i>N. Shibata</i>	DIMENSION TOLERANCE	ANGULAR TOLERANCE	FINISH	
CHECKED	<i>J.L. Shimizu</i>	—	—	—	
DESIGNED	<i>Shuya Kataoka</i>	RUST PREVENTION	MATERIAL		
DRAWN	<i>Shuya Kataoka</i>	—	—		
SCALE	UNIT	DIAGRAM METHOD	PART NAME		
1:1	mm	THIRD ANGLE PROJECTION	EVFP-φ38 ***A		
DRAWING DATE	DRAWING NAME	3D CAD DATA	PART NO.		
03/JUL/2020	G2979-0-2	—	SEE TABLE ON PAGE 1/2		
Pacific Engineering Corporation				SHEET	SIZE
				2 / 2	A3